

O. & W. WRIGHT.
 MECHANISM FOR FLEXING THE RUDDER OF A FLYING MACHINE OR THE LIKE.
 APPLICATION FILED JULY 15, 1908.

908,929.

Patented Jan. 5, 1909.

2 SHEETS—SHEET 1.

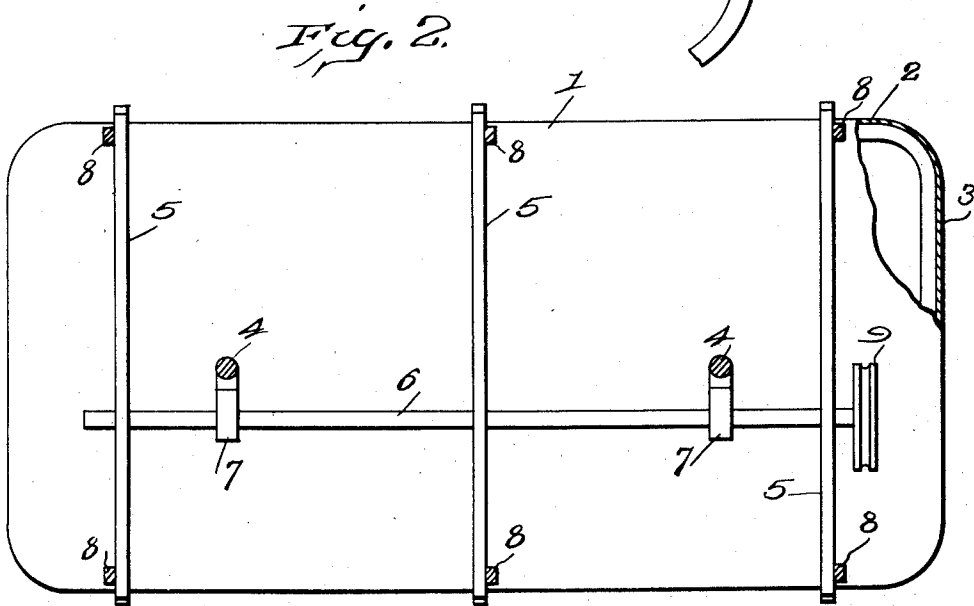
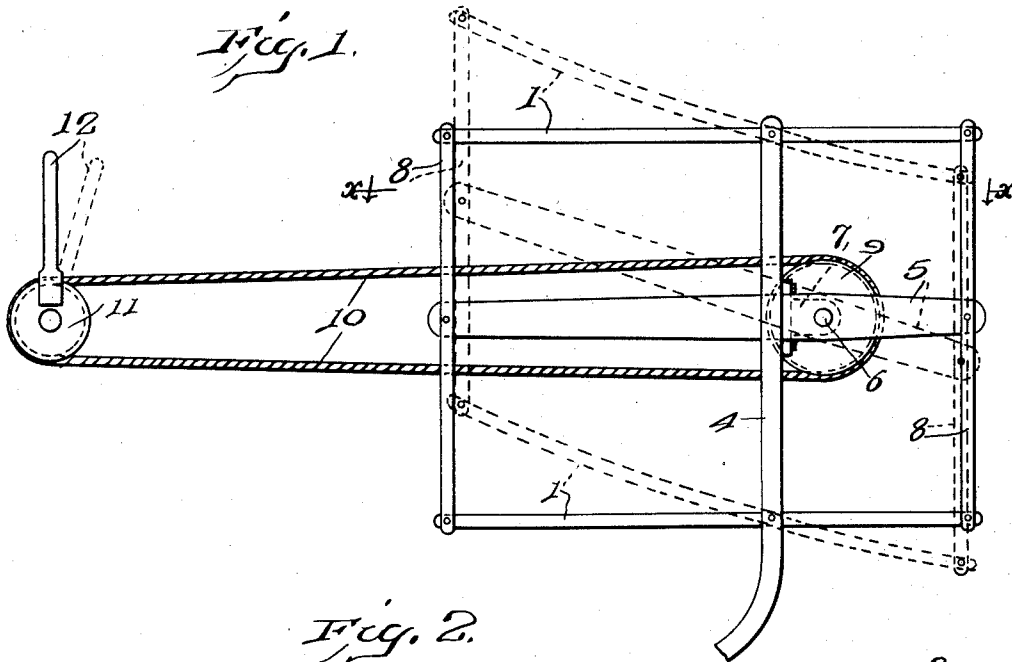

Witnesses

G. Howard Walmley.
Edward L. Reed.

Inventors
Orville Wright,
Wilbur Wright,

By *H. A. Gouluin,*
 Attorney

O. & W. WRIGHT.
 MECHANISM FOR FLEXING THE RUDDER OF A FLYING MACHINE OR THE LIKE.
 APPLICATION FILED JULY 15, 1908.

908,929.

Patented Jan. 5, 1909.

2 SHEETS—SHEET 2.

Fig. 3.

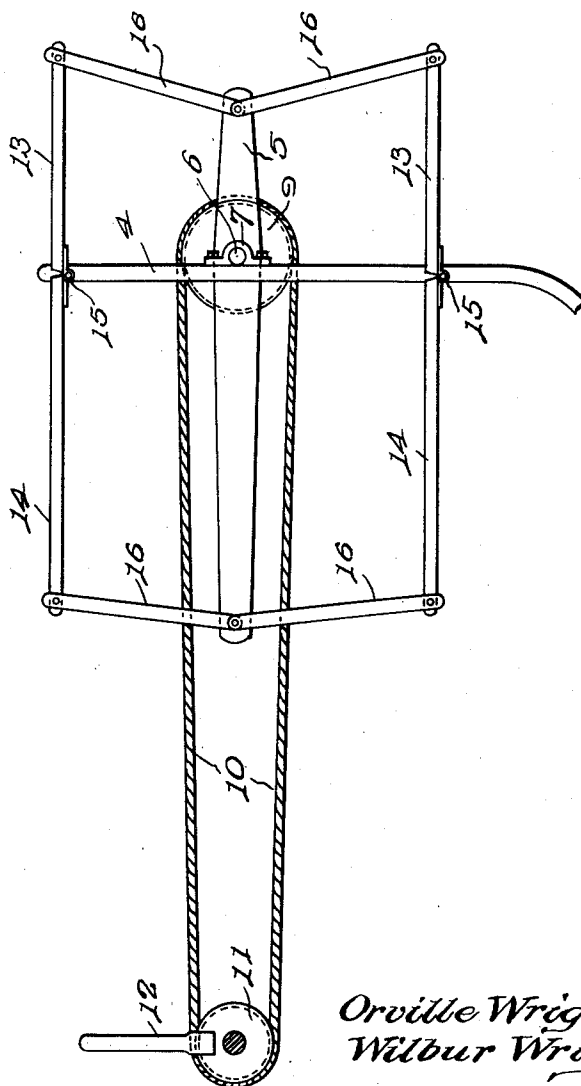

Witnesses

G. Howard Walmsley.
Edward Reed.

Inventors
Orville Wright,
Wilbur Wright,

By *H. A. Faulstich,*
 Attorney

UNITED STATES PATENT OFFICE.

ORVILLE WRIGHT AND WILBUR WRIGHT, OF DAYTON, OHIO.

MECHANISM FOR FLEXING THE RUDDER OF A FLYING-MACHINE OR THE LIKE.

No. 908,929.

Specification of Letters Patent.

Patented Jan. 5, 1909.

Application filed July 15, 1908. Serial No. 443,718.

To all whom it may concern:

Be it known that we, ORVILLE WRIGHT and WILBUR WRIGHT, citizens of the United States, residing at Dayton, in the county of Montgomery and State of Ohio, have invented certain new and useful Improvements in Mechanism for Flexing the Rudder of a Flying-Machine or the Like, of which the following is a specification, reference being had therein to the accompanying drawings.

This invention relates to mechanism for actuating the rudders or controlling planes of aeronautical machines, and is in the nature of an improvement upon the mechanism shown and described in the patent granted to us May 22, 1906, No. 821,393.

The object of this invention is to provide a mechanism whereby both the front and rear edges of a flexible rudder will be positively actuated at different angular velocities to adjust the rudder to the desired angle relative to its normal position, and to simultaneously flex the rudder in such a manner as to present the rear portion thereof to the action of the wind at a greater angle than the forward portion, thereby greatly increasing the effectiveness of the rudder.

With this object in view our invention consists in certain novel features of construction and in certain combinations and arrangements of parts to be hereinafter described, and then more particularly pointed out in the claims.

In the accompanying drawings, Figure 1 is an end elevation of a rudder embodying our invention; Fig. 2 is a transverse sectional view, taken on the line $x-x$ of Fig. 1 and looking in the direction of the arrows; and Fig. 3 is an end elevation showing a modified form of the invention.

In carrying out our invention we have applied the same to a flexible rudder 1, which, in its normal position, is substantially flat and has both its front and rear edges in substantially the same plane with the body portion of the rudder. This rudder may be of any suitable construction, but preferably comprises a skeleton frame consisting of the longitudinal members 2 and the transverse members 3 extending between the longitudinal members, this frame having a suitable covering of fabric or other material. The flexibility of the frame may be secured in any desired manner, but we prefer to accomplish this by forming the trans-

verse members or rods 3 of flexible material, such as strips of wood which have the necessary strength combined with a certain amount of flexibility. Suitable means are provided for positively actuating both the front and rear edges of this rudder to turn the same to the desired angle relative to its normal position, and, at the same time, to flex the rudder in such a manner as to present a concave surface to the action of the wind, the forward portion of which surface will present a small angle of incidence to the wind, which angle of incidence will rapidly increase toward the rear.

For purposes of illustration we have, in the present instance, shown the flexible rudder 1 as a horizontal rudder mounted on suitable supports 4 carried by some part of the machine to which the rudder is attached. The rudder is pivotally connected to the support at a point intermediate its ends and preferably slightly in front of a line equidistant from the front and rear edges of the rudder. The operating mechanism, in the present instance, comprises one or more levers 5, with arms of unequal lengths, pivotally supported near the rudder 1, having their arms of different lengths than the corresponding arms of the transverse members or rods of the rudder, and having their pivotal centers eccentrically arranged relative to the pivotal center of said rudder and having their opposite ends connected to the front and rear edges, respectively, of said rudder. In the present instance, we have provided three of these levers 5 and have shown the same as rigidly secured to a shaft 6 extending longitudinally of the rudder and journaled in forwardly extending bearing brackets 7 secured to the upright members 4. These levers are connected at their opposite ends to the adjacent edges of the rudder by means of links 8. The rudder may consist of one, or more than one plane. In the present instance, we have shown the rudder as a double rudder comprising two single rudders or planes 1, each of these planes having its front and rear edges, respectively, connected to the adjacent ends of the levers 5 by the links 8, whereby both planes or rudders are simultaneously actuated when the levers are moved, the links 8 forming connecting rods between the adjacent edges of the two rudders. These connecting rods, which are formed by the links 8, have a certain amount

of flexibility owing to the pivotal connection between the adjacent ends of the two links, and this flexibility enables those portions of the rods to which the levers 5 are
5 connected to move laterally to accommodate themselves to the movement of the ends of these levers, which, owing to the eccentric arrangement of the pivotal centers of the levers, is different from the movement of
10 the edges of the planes or rudders.

Any suitable mechanism may be provided for operating the shaft 6 and the levers 5. In the present instance, we have mounted on the shaft 6 a drum 9, about which extends
15 an endless cable 10 which also extends about a drum 11 rotatably mounted on the aeroplane, or other machine to which the rudder is attached, and provided with a handle 12 for rotating the same. Thus, it
20 will be apparent that by the actuation of the drum 11 on the machine the shaft 6 and the levers 5 carried thereby will be moved about their pivotal center and that this movement of the levers will positively
25 move the front and rear edges of the rudder in opposite directions to tilt the same at the desired angle to their normal or horizontal position, and that, owing to the different ratio between the arms of the lever
30 and the arms of the rudder and to the eccentric arrangement of the pivotal centers of the levers relative to the pivotal center of the rudder, the opposite edges of the rudder will be moved at different angular velocities
35 with reference to their pivotal center, thus flexing the rudder in such a manner as to present a concave surface to the action of the wind, the forward portion of the rudder having a small angle of incidence,
40 which angle of incidence rapidly increases toward the rear, thus greatly increasing the efficiency of the rudder.

As above stated, the flexibility of the rudders or planes may be secured in any suitable manner and we have, in Fig. 3 of the drawings, illustrated a modified form of the device in which this flexibility is secured by forming the planes of which the rudder is
45 comprised in sections and pivotally connecting these sections one to the other in such a manner that, when the sections of the rudder are moved about their pivotal centers at different angular velocities, the forward and rearward portions of the rudder
55 will be presented to the wind at different angles of incidence. As shown in this figure the upper and lower planes each consist of a forward portion 13 and a rearward portion 14, the rearward portion being
60 preferably of considerably greater width than the forward portion. These sections have their adjacent edges pivotally connected one to the other by means of hinges 15, the point of connection being preferably in
65 substantially the same vertical plane with

the supporting standards 4. The sections of the planes may be moved about their pivotal centers at different angular velocities by means of the levers 5, which, as in the form of the device above described, have
70 their arms of different lengths than the widths of the corresponding portions or sections of the plane or rudder. In this form of the device we have also shown the shaft 6 as mounted directly upon the upright
75 supports 4 and in approximately the same vertical plane therewith and have shown the links 16, which connect the ends of the levers 5 with the outer edges of the corresponding sections of the planes or rudders,
80 as inclined relatively to said plane, thus compensating for the difference between the lengths of the arms of the levers and the widths of the corresponding sections of the plane.
85

We wish it to be understood that we do not desire to be limited to the details of construction shown and described, for obvious modifications will occur to a person skilled in the art.
90

Having thus fully described our invention, what we claim as new and desire to secure by Letters Patent, is:—

1. In a mechanism of the character described, the combination, with a flexible
95 rudder having its opposite edges normally in substantially the same plane with the body thereof, of means for positively actuating both edges of said rudder at different angular velocities with reference to the pivotal center of said rudder.
100

2. In a mechanism of the character described, the combination, with a pivoted rudder having its opposite edges normally in substantially the same plane with the
105 body thereof, of means for positively moving the front and rear edges of said rudder in opposite directions and at different angular velocities.

3. In a mechanism of the character described, the combination, with a normally flat and substantially horizontal flexible,
110 pivoted rudder, of means for positively actuating both edges of said rudder at different angular velocities to flex said rudder in such a manner as to present a concave surface to the action of the wind.
115

4. In a mechanism of the character described, the combination, with a support, and a rudder pivotally mounted on said support and having its front and rear portions normally in substantially the same plane with its pivotal center, of a lever pivotally supported near said rudder and having its pivotal center eccentrically arranged relative to the pivotal center of said rudder,
120 means for connecting the ends of said lever to the adjacent edges of said rudder, and means for actuating said lever.
125

5. In a mechanism of the character de-
130

scribed, the combination, with a support, and a flexible rudder pivotally mounted on said support and having its opposite edges normally in substantially the same plane with its pivotal center, of a shaft carried by said support and arranged eccentrically to the pivotal center of said rudder, a plurality of levers mounted on said shaft and having their opposite ends connected to the front and rear edges, respectively, of said rudder, and means for actuating said shaft.

6. In a mechanism of the character described, the combination, with a plurality of supports, and a flexible rudder pivotally mounted on said supports and having its opposite edges normally in substantially the same plane with its pivotal center, of a plurality of forwardly extending brackets carried by said supports, a shaft journaled in said brackets, a plurality of levers rigidly secured to said shaft, links connecting the opposite ends of said levers to the front and rear edges, respectively, of said rudder, and means for actuating said shaft.

7. In a mechanism of the character described, the combination, with a plurality of supports, a rudder comprising upper and lower flexible planes pivotally connected to said supports, connecting rods extending between the adjacent edges of said planes, levers pivotally mounted on said supports and having their pivotal centers arranged eccentrically to the pivotal centers of said planes and their opposite ends connected to said connecting rods, and means for simultaneously actuating said levers.

8. In a mechanism of the character described, the combination, with a plurality of supports, and a rudder comprising upper and lower planes pivotally mounted on said

supports, of a bracket carried by each of said supports, a shaft journaled in said brackets, a plurality of levers rigidly secured to said shaft extending transversely of said planes, links connecting the adjacent ends of said levers to the front and rear edges, respectively, of said upper and lower planes, and means for actuating said shaft.

9. In a mechanism of the character described, the combination, with a rudder having forward and rearward portions normally in a single plane, of means for positively moving both the front and rear portions of said rudder at different angular velocities with reference to the pivotal center of said rudder to present the rear portion at a greater angle of incidence than the forward portion.

10. In a mechanism of the character described, the combination, with a rudder having its front and rear edges normally in substantially the same plane with the body portion thereof, of means for positively actuating both the front and rear edges of said rudder to adjust the rudder at an angle to its normal position and to flex said rudder.

In testimony whereof we affix our signatures in the presence of two witnesses.

ORVILLE WRIGHT.
WILBUR WRIGHT.

Witnesses to the signature of Orville Wright:

C. E. TAYLOR,
C. W. FURNAS.

Witnesses to the signature of Wilbur Wright:

HART O. BERG,
DEAN B. MASON.