

A. & L. LUMIÈRE.
KINETOGRAPHIC CAMERA.

No. 579,882.

Patented Mar. 30, 1897.

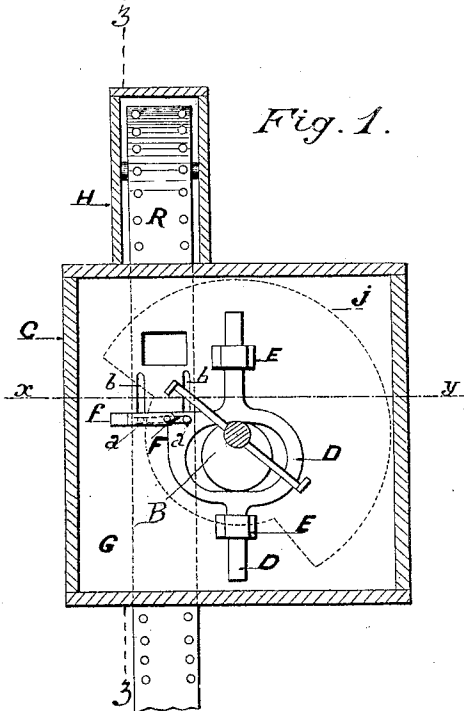

Fig. 1.

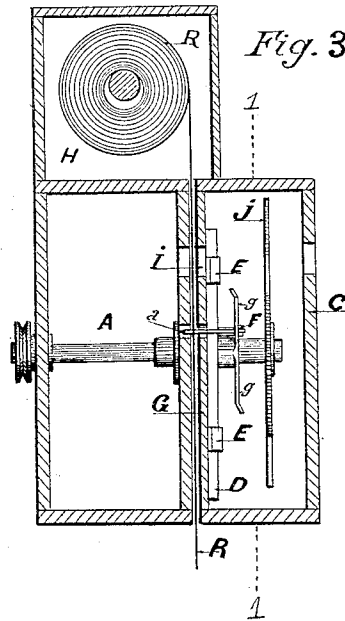

Fig. 3.

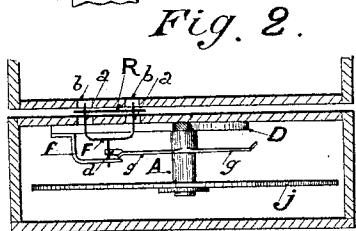

Fig. 2.

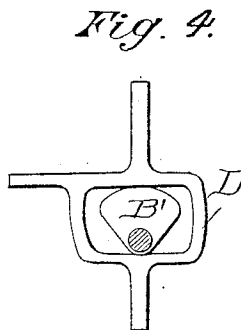

Fig. 4.

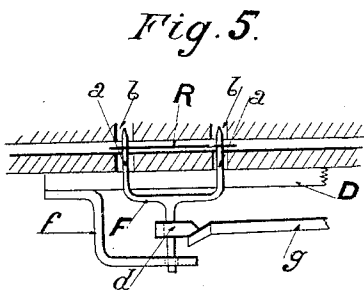

Fig. 5.

Witnesses
 H. van Oldenmel
 E. A. Scott

Inventors
 Auguste Lumière
 Louis Lumière
 by *[Signature]*
 Attorneys

(No Model.)

2 Sheets—Sheet 2.

A. & L. LUMIÈRE.
KINETOGRAPHIC CAMERA.

No. 579,882.

Patented Mar. 30, 1897.

FIG. 5.

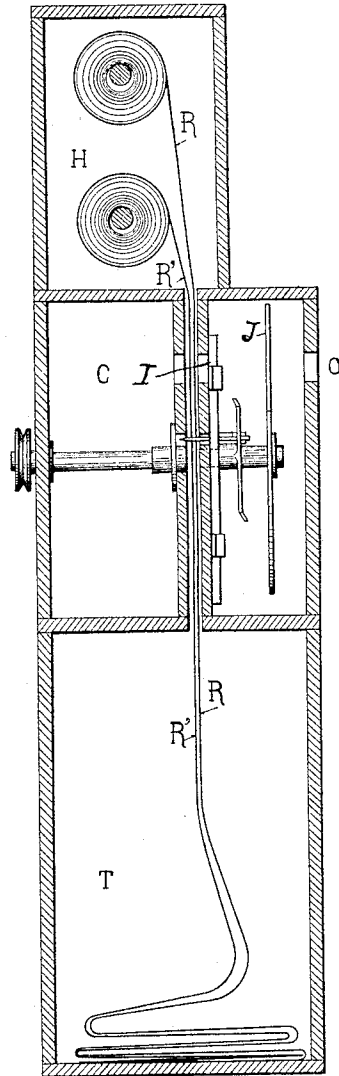

Witnesses

H. van Oldenmeel
E. A. Scott

Inventors
Auguste Lumière
Louis Lumière

by *Richardson*

Attorneys

UNITED STATES PATENT OFFICE.

AUGUSTE LUMIÈRE AND LOUIS LUMIÈRE, OF LYONS, FRANCE.

KINETOGRAPHIC CAMERA.

SPECIFICATION forming part of Letters Patent No. 579,882, dated March 30, 1897.

Application filed September 6, 1895. Serial No. 561,716. (No model.) Patented in France February 13, 1895, No. 245,032; in Belgium April 4, 1895, No. 114,911; in Austria April 13, 1895, No. 2,808; in Spain April 15, 1895, No. 17,295; in Italy April 15, 1895, LXXV, 460; in England December 10, 1895, No. 7,187; in Germany January 8, 1896, No. 84,722; in Luxemburg March 2, 1896, No. 2,461; in Norway March 7, 1896, No. 5,003; in Hungary March 9, 1896, No. 5,855, and in Switzerland June 4, 1896, No. 10,034.

To all whom it may concern:

Be it known that we, AUGUSTE LUMIÈRE and LOUIS LUMIÈRE, citizens of the Republic of France, residing at Lyons, France, have invented certain new and useful Improvements in Photographic Apparatus, of which the following is a specification.

The invention has been patented in France February 13, 1895, No. 245,032; in England December 10, 1895, No. 7,187; in Germany January 8, 1896, No. 84,722; in Austria April 13, 1895, No. 2,808; in Belgium April 4, 1895, No. 114,911; in Spain April 15, 1895, No. 17,295; in Italy April 15, 1895, LXXV, 460; in Switzerland, provisional, April 6, 1895, final, June 4, 1896, No. 10,034; in Hungary March 9, 1896, No. 5,855; in Luxemburg March 2, 1896, No. 2,461, and in Norway March 7, 1896, No. 5,003.

Our invention is designed to take a series of negatives at regular short intervals of time.

In the annexed drawings, Figure 1 is a front view of the operating mechanism, the casing therefor being in section. Fig. 2 is a horizontal section through xy of Fig. 1. Fig. 3 is a perpendicular section of Fig. 1 on line 3 3 of Fig. 1. Fig. 4 is a modification of the means for actuating the parts. Fig. 5 is an enlarged detail view of the means for moving the ribbon. Fig. 6 is a sectional view of the apparatus for taking positive prints.

The mechanism is inclosed by a box G and is controlled by an axis A, which is moved by a motor of any kind. Upon the axis A is mounted an eccentric B, which moves a vertical slide D, having arms fitting guides E E.

Upon an extension of this slide is mounted a light fork F, (shown enlarged in Fig. 5,) its two points $a a$ passing through elongated openings $b b$ in partition G. The fork F has a projection guided by a bracket f and moves horizontally. This projection has a piece d fixed to it, with a double inclined end in the path of two arms $g g$, fixed to the axis A, and having their extremities bent in opposite directions, as shown, and adapted to contact with the inclined end of d to move the same.

In rear of partition G is a vertical passage through which a perforated ribbon R passes from a box H, placed on the upper part of the apparatus. The perforations of this ribbon are near the edges, at equal distance apart, and are traversed by the two points $a a$ of the fork F. At the moment when the fork is pushed inward by one of the branches g the slide d begins to descend and thus moves the ribbon. At the end of this course the fork is pushed back by the second branch g , and this disengages the points a from the perforations, and the slide moves back without acting upon the ribbon.

It will be seen that the ribbon is thus moved during the descending course of points a , but is stationary during their upward movement, and that the same points connect and disconnect with the ribbon without shock, and consequently without spoiling the perforations.

The ribbon rolls very easily down from box H, where it is simply maintained upon a fixed axis.

Partition G is provided with an exposure-opening I of a size equal to one of the successive pictures. This exposure-opening is alternately opened or closed by a disk J, the outlines of which can be seen in Fig. 1.

The disk J has a cut-away part intended to uncover the window I during the time that the ribbon is stationary.

The apparatus can be used for the following purposes:

First, to produce negative images upon a ribbon R, Figs. 1 and 3, either of film or of transparent paper, sensitized and with perforated edges, as has been explained. The chamber C being closed and provided with an objective placed in front of the exposure-opening I, the animated scene it is desired to reproduce is posed before said objective. The successive phases of said animated scenery will be impressed upon the ribbon R during the time it is stationary and while it is uncovered by the disk. In such a manner it is possible to produce very clear impressions, which succeed one another very rapidly upon the entire length of the ribbon. The

impressed band descends in a dark room placed underneath the apparatus, wherefrom it is taken when it is desired to proceed to the developing of the negatives.

5 Second, the same apparatus can serve also to make positive proofs. (See Fig. 6.) The ribbon R previously obtained, and which carries the negative impressions, is placed upon a roller in the box II. A second roller is
10 placed under the same in the same chamber and carries a second sensitized ribbon R', perforated as the former and adapted to receive the positive impressions. That ribbon
15 may or may not be transparent, according to whether the figures are to be viewed by transmitted or reflected light. The two superposed ribbons are actuated together by the mechanism while the light penetrates through the front opening O. During the operation the
20 speed must be regulated according to the degree of light and the sensitiveness of the ribbon R', in order that the latter can at each time of repose be sufficiently impressed by the light passing through the negative image on the ribbon R. Both ribbons drop together
25 in the dark room T and are withdrawn from there, and the ribbon R' is developed and fixed.

30 Third, the apparatus serves, besides, to allow the projection of the positive images produced upon the ribbon R' during the preceding operation. To that effect the ribbon which has been placed upon a roller in the chamber II, Figs. 1 and 2, will again be operated
35 by the mechanism, and the positive images being conveniently illuminated will be seen directly or projected upon a screen.

40 These pictures will absolutely succeed in the same manner and will return exactly to the same place where the impressions were made during the shift. They will be visibly isolated in a state of complete rest and during a nearly equal time of interruption between two pictures, which are very favorable
45 conditions for the clearness and continuousness of the vision. It will, moreover, be possible by means of different-shaped cams B'—as, for instance, the triangular cam represented in Fig. 4—to augment the times of rest
50 of the ribbon up to two-thirds of the total time, which is a very favorable condition either for the direct vision or projection and to obtain the pictures in relatively greater intervals.

55 For the observation, be it direct or by projection, we use a sloped disk made of a translucent material, oiled or paraffined paper, celluloid, &c., which are intended to diminish the scintillation due to the periodic suppression of the light.

60 We claim—

1. In combination, the reciprocating slide,

the rotary shaft, the points operated by the slide for engaging a ribbon, the disk on the main shaft arranged to expose the ribbon, at intervals, substantially as described.

2. In combination the casing having an aperture and adapted to receive a ribbon, the main shaft, the disk thereon, the slide operated from the main shaft, the points carried by the slide and movable in relation thereto and the arms on the main shaft to control the advanced and retracted position of the points relative to the slide and ribbon and their engagement with the ribbon.

3. In combination, the casing having an aperture and adapted to receive a ribbon, the main shaft, the eccentric thereon, the slide operated by the eccentric, the points carried by the slide, means controlling the engagement of the points with the ribbon, and the disk on the shaft of the eccentric, substantially as described.

4. In combination with the ribbon guide and holder, the fork having points for engaging the ribbon and means for reciprocating the fork, substantially as described.

5. In combination with the ribbon guide and support, the fork having the points for engaging the ribbon and means for giving the fork both a reciprocatory movement lengthwise of the ribbon and a reciprocation toward and from the same, substantially as described.

6. In combination with the ribbon-guide, the disk with means for rotating the same, said disk having an indent to expose the ribbons at intervals, and means for moving the ribbon, the two ribbon-supports whereby a pair of ribbons may be superposed in order to take a positive impression, substantially as described.

7. In combination, the ribbon-guides, the disk, the casing, the slide moving parallel to the course of the ribbon, the points movable through the slide substantially at right angles to the ribbon and means for operating the slide and points, substantially as described.

8. In combination a casing, a main shaft, a ribbon-moving slide having means to engage the ribbon, a disk on the main shaft and the connection from the shaft to the slide.

9. In combination, the casing with the ribbon-guide, the rotary disk, the shaft carrying the same, the slide, the points carried thereby and movable independently thereof and means carried by the disk-shaft for reciprocating the slides and for moving the points.

In witness whereof we have hereunto set our hands in presence of two witnesses.

AUGUSTE LUMIÈRE.
LOUIS LUMIÈRE.

Witnesses:

GASTON JEUNNIUS,
MARIUS VACHON.